



STANDARD



APPLICATIONS

This Landscape spot light series is an ideal solution for general site, landscape, sign and pathway lighting. Constructed of a die cast aluminum housing, and a polycarbonate lens with seamless silicone gasket to prevent leaks, it will stand up to many years of punishing environmental conditions. High-efficacy, long-life LEDs provide both energy and maintenance cost savings compared to traditional, incandescent landscape lights.

FEATURES

- * Color temperature: 3000K, 4000K, 5000K selectable
- * Available in 13w and 25 W
- * Long-life LEDs provide 50,000 hours of operation with at least 70% of initial lumen output (L70)
- * Waterproof rating: IP65
- * Universal 100-277 VAC input
- * Phillips Lumiled 2835 chips
- * 0-10V diming standard
- * Power factor > 0.90
- * Color rendering index > 80
- * Die cast aluminum housing with durable, Dark bronze powder coat paint.
- * Polycarbonate lens
- Beam Angle (50%) : 45 degrees
- Beam Angle (10%): 85 degrees
- * Easy installation in new construction or retrofit

ORDERING INFORMATION

PART #	CCT Color Temp	Wattage	Lumens			Lumens per Watt			Mounting options
			30K	40K	50K	30K	40K	50K	
CLL-FL17-13W-CCT	30K, 40K, 50K	13	1,755	1950	1820	135	150	140	Canopy Mount CLL-FL17-PLATE
CLL-FL17-25W-CCT	30K, 40K, 50K	25	3,250	3625	3375	130	145	135	Spike mount DTH-LNDSL-BS

WARRANTY & DETAILS

- * UL listed
- * Energy Star approved
- * 5-year warranty on all electronics and housing

DIMENSIONS

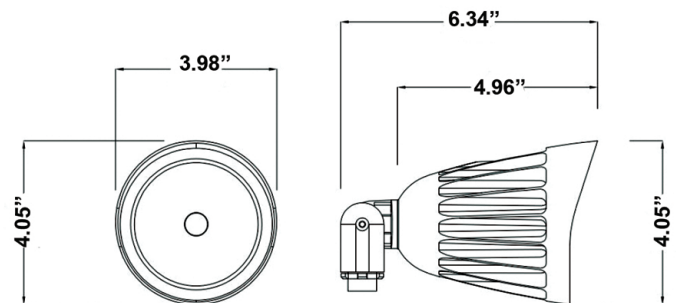

MOUNTING OPTIONS

- * Threaded pipe (NPT 1/2"), which attaches to a junction box, is standard
- * Optional spike-mount (DTH-LNDSL-BS) for ground mounting
- * Optional canopy-mount (CLL-FL17-PLATE) for attachment to flat surface. Enclosure is sealed with a

